



XL741 & 741SE

Discrete Operational Amplifiers

Re-create one of the most classic, popular, and all-around useful chips of all time.

The XL741 and 741SE Discrete Operational Amplifiers are faithful and functional transistor-scale replicas of the classic μ 741 op-amp integrated circuit.

Design by Eric Schlaepfer (tubetime.us), working in collaboration with Evil Mad Scientist Laboratories.

The latest version of this document and additional resources about '741 op-amps are available at: <https://wiki.evilmadscientist.com/741>

Main Specifications

- Kit type: Through-hole soldering kit (XL741) or Surface mount soldering kit (741SE)
- Assembly instructions: Printed, included with kit
- Function: Equivalent circuit to μ 741 op-amp IC. Some performance characteristics differ; Refer to Abs. Maximum ratings and Electrical Characteristics
- RoHS compliance: All kit components are RoHS compliant (lead free)
- Connection methods: Terminal posts (bare wire, lug, or alligator clip) or solder

Connection Diagram / Pinout

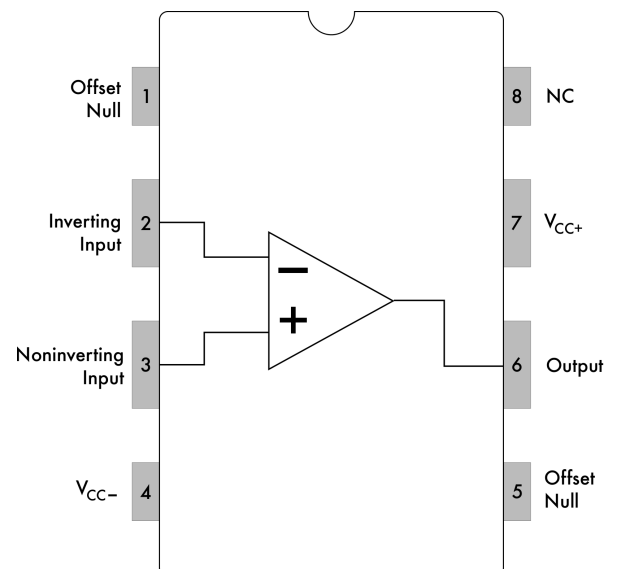

Kit Contents: "XL741" Through-hole soldering kit

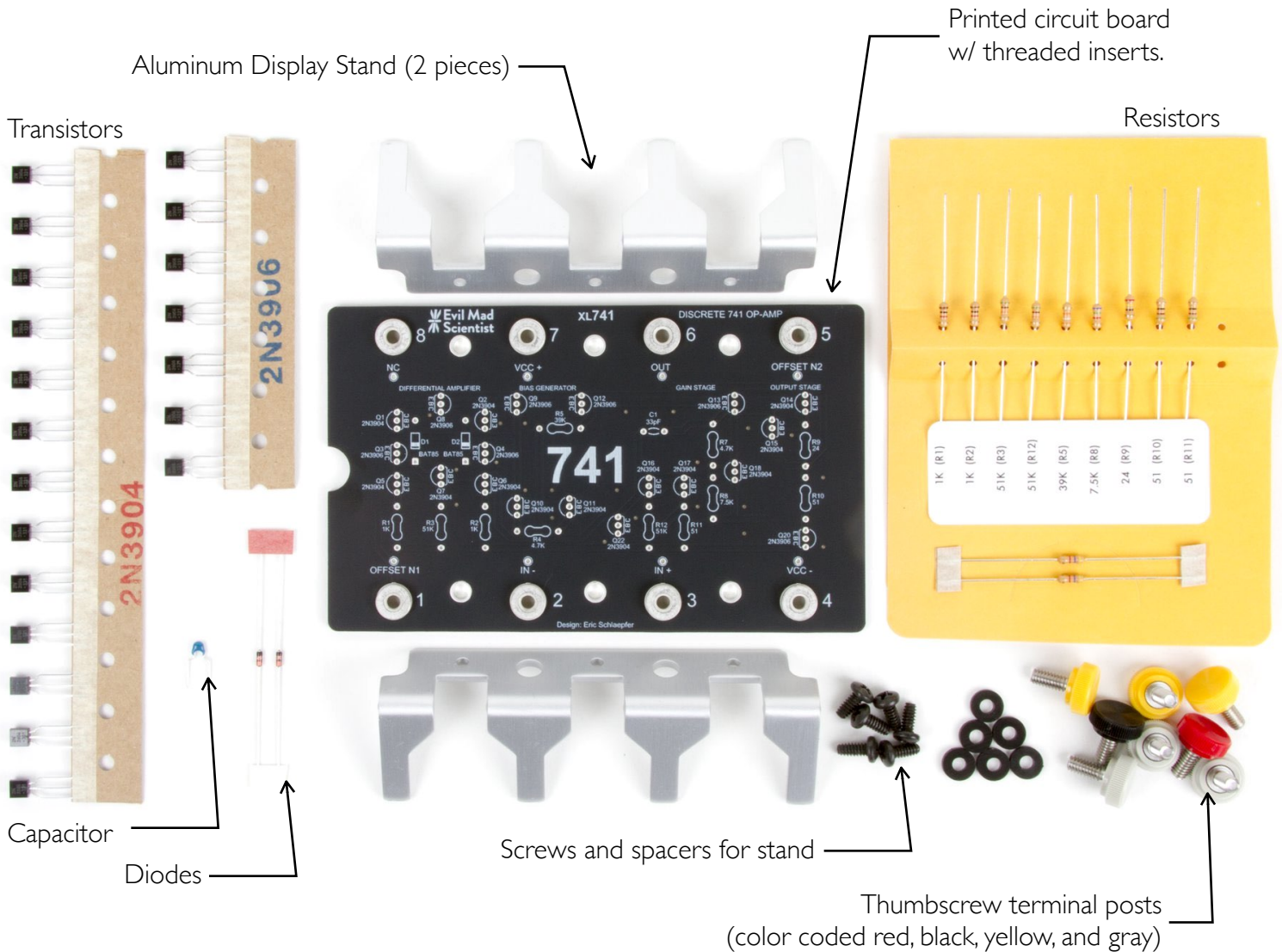

Contents of the XL741 kit:

- The XL741 printed circuit board (extra thick 0.100"), pre-fitted with eight 8-32 threaded inserts
- The transistors, resistors, diodes and capacitor required to assemble the kit
- Eight thumbscrews (terminal posts) with color-coded caps
- Two-piece "IC Legs" stand, anodized aluminum
- Mounting screws and spacers for attaching the "IC Legs" stand
- Printed assembly instructions (not shown)

Tools and materials required for assembly (not included with kit):

- Soldering iron
- Solder
- Wire clippers
- Phillips head screwdriver (#2 size recommended).



Completed kit

Kit Contents: “741SE” Surface-mount soldering kit

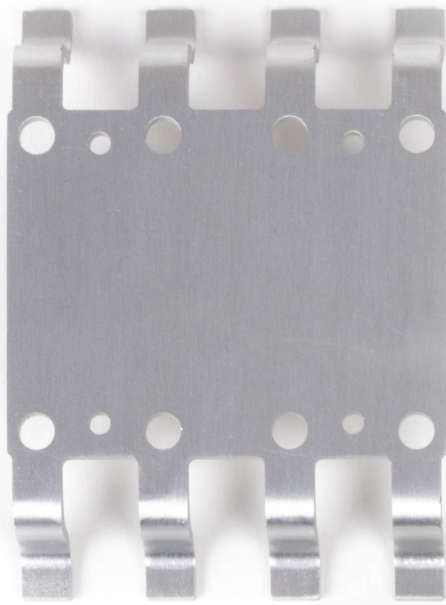

Aluminum Display Stand

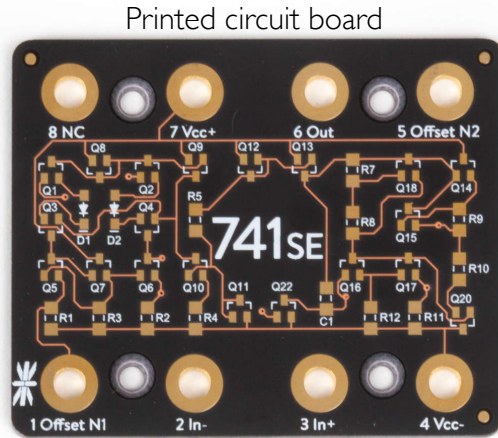

Printed circuit board

Screws and spacers for stand



Threaded inserts for circuit board



Thumbscrew terminal posts: color coded red, black, yellow, and gray



Surface mount components: Resistors (1206 size), transistors (SOT-23), diodes, capacitor. (Example parts, shown enlarged)

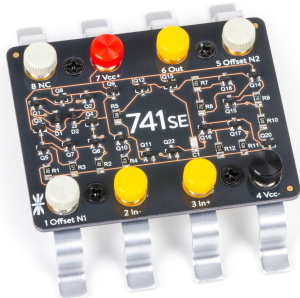

Completed kit

Contents of the 741SE Surface-mount Soldering Kit:

- The 741SE printed circuit board (black with clear mask and visible traces)
- Surface mount threaded inserts
- The transistors, resistors, diodes and capacitor required to assemble the kit
- Eight thumbscrews (terminal posts) with color-coded caps
- Single-piece “SOIC Legs” stand, anodized aluminum
- Mounting screws and spacers for attaching the stand
- Printed assembly instructions (not shown)

Tools and materials required for assembly (not included with kit):

- Solder (paste or wire)
- Soldering iron (or other surface mount soldering equipment)
- Fine-point metal tweezers
- Phillips head screwdriver (#1 size recommended).

Schematic Diagram

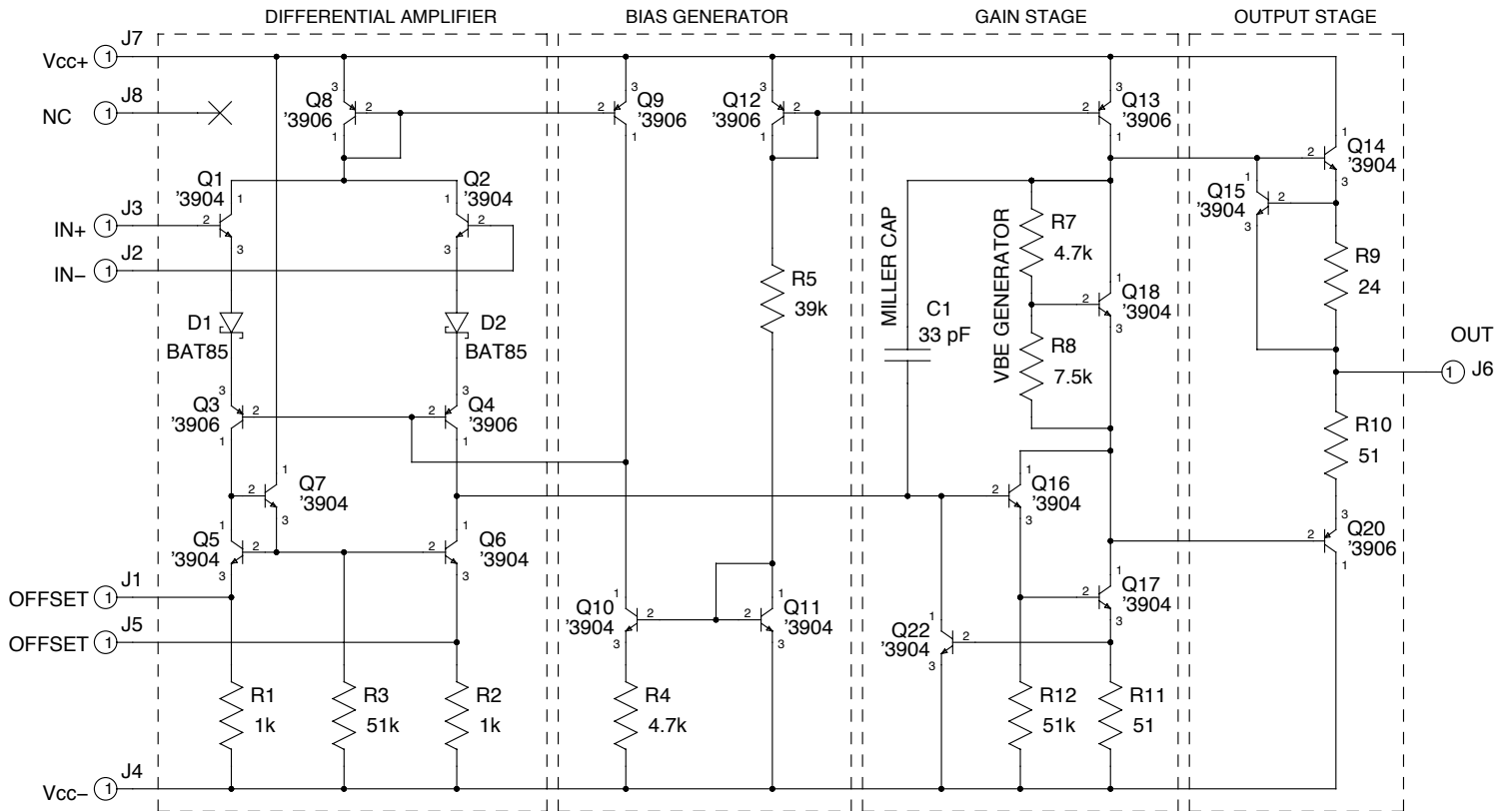

Electrical Components

Reference	Qty	Type	Value (xL741)	Value (741SE)
Q1,2,5,6,7,10,11,14-18,22	13	NPN Transistor	2N3904	MMBT3904
Q3,4,8,9,12,13,20	7	PNP Transistor	2N3906	MMBT3904
R1,R2	2	Resistor	1 k Ω	1 k Ω
R3,R12	2	Resistor	51 k Ω	51 k Ω
R4,R7	2	Resistor	4.7 k Ω	4.7 k Ω
R5	1	Resistor	39 k Ω	39 k Ω
R8	1	Resistor	7.5 k Ω	7.5 k Ω
R9	1	Resistor	24 Ω	24 Ω
R10,R11	2	Resistor	51 Ω	51 Ω
C1	1	Cap., Ceramic	33 pF	33 pF
D1,D2	2	Diode, Schottky	BAT85	BAT54

Absolute Maximum Ratings¹

Parameter	Symbol	Value	Unit
Supply Voltage, Positive ²	V_{CC+}	+18	V
Supply Voltage, Negative	V_{CC-}	-18	V
Differential Input Voltage ³	V_{ID}	± 30	V
Input Voltage (any input) ⁴	V_{IN}	Lesser of V_{CC} or ± 15	V

Notes:

1. Exceeding Absolute Maximum Ratings may cause permanent damage to the device. Please refer to Electrical Characteristics for recommended operating parameters.
2. Input voltages are measured with respect to the midpoint between V_{CC+} and V_{CC-} .
3. Differential Input Voltage is the voltage at pin IN+ with respect to the voltage at pin IN-.
4. Input voltages must not exceed V_{CC} nor 15 V in magnitude.

Electrical Characteristics

At $V_{CC} = \pm 15 \text{ V}$, $T_A = 25 \text{ }^\circ\text{C}$ (unless otherwise specified)

Parameter	Symbol	Conditions	Typ	Unit
Input Offset Voltage	V_{IO}	$R_S \leq 10 \text{ k}\Omega$	2	mV
Input Offset Current	I_{IO}		20	nA
Input Bias Current	I_{IB}		80	nA
Input Resistance	r_i		2	M Ω
Input Capacitance ¹	C_i		10	pF
Offset Voltage Adjustment Range	$\Delta V_{IO(ADJ)}$		± 15	mV
Input Voltage Range (Common Mode)	V_{IR}		± 13	V
Common Mode Rejection Ratio ¹	CMRR	$R_S \leq 10 \text{ k}\Omega$	43	dB
Supply Voltage Sensitivity	$\Delta V_{IO}/\Delta V_{CC}$	$R_S \leq 10 \text{ k}\Omega$	30	$\mu\text{V}/\text{V}$
Large-Signal Differential Voltage Gain	A_{VD}	$R_L \geq 2 \text{ k}\Omega$, $V_{OUT} = \pm 10 \text{ V}$	200	V/mV
Output Voltage Swing	V_{OM}	$R_L \geq 10 \text{ k}\Omega$	± 14	V
		$R_L \geq 2 \text{ k}\Omega$	± 13	V
Output Resistance	r_o		75	Ω
Output Short-Circuit Current	I_{OS}		25	mA
Supply Current	I_{CC}	$V_O = 0 \text{ V}$, No load	1.7	mA
Power Consumption	P_D	$V_O = 0 \text{ V}$, No load	50	mW
Transient Response (unity gain)		$V_{in} = 20 \text{ mV}$, $R_L = 2 \text{ k}\Omega$, $C_L \leq 100 \text{ pF}$		
Risetime	t_r	$V_{CC} = 5 \text{ V}$	0.3	μs
Overshoot			5	%
Slew Rate	SR	$R_L \geq 2 \text{ k}\Omega$	0.5	V/ μs

Notes:

- Note that this value differs significantly from the $\mu\text{A}741$ integrated circuit.

Block Diagram

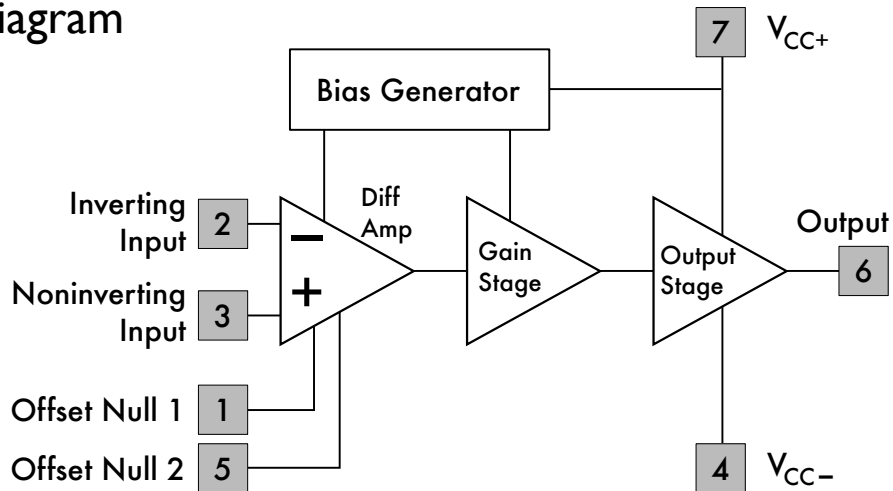

Example Circuits

Voltage Follower (analog buffer):

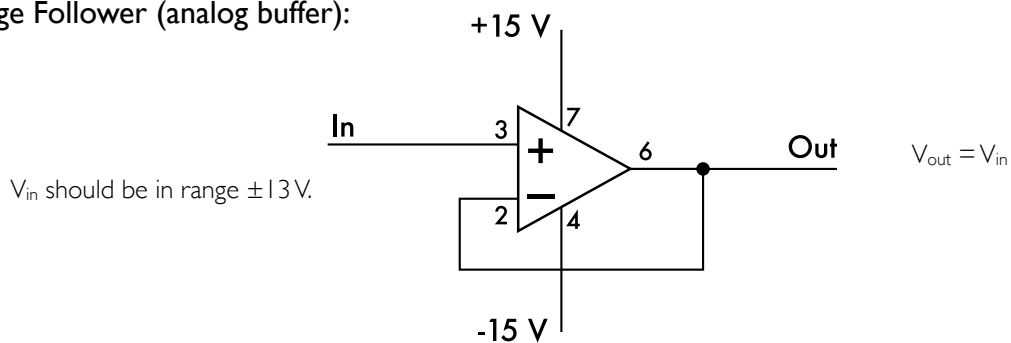

Inverting Amplifier

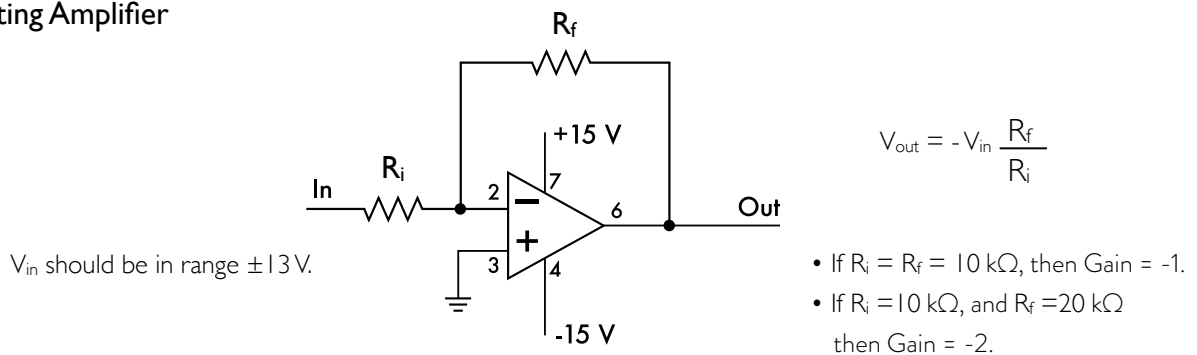

XL741 Package information: Circuit board physical layout and mounting holes

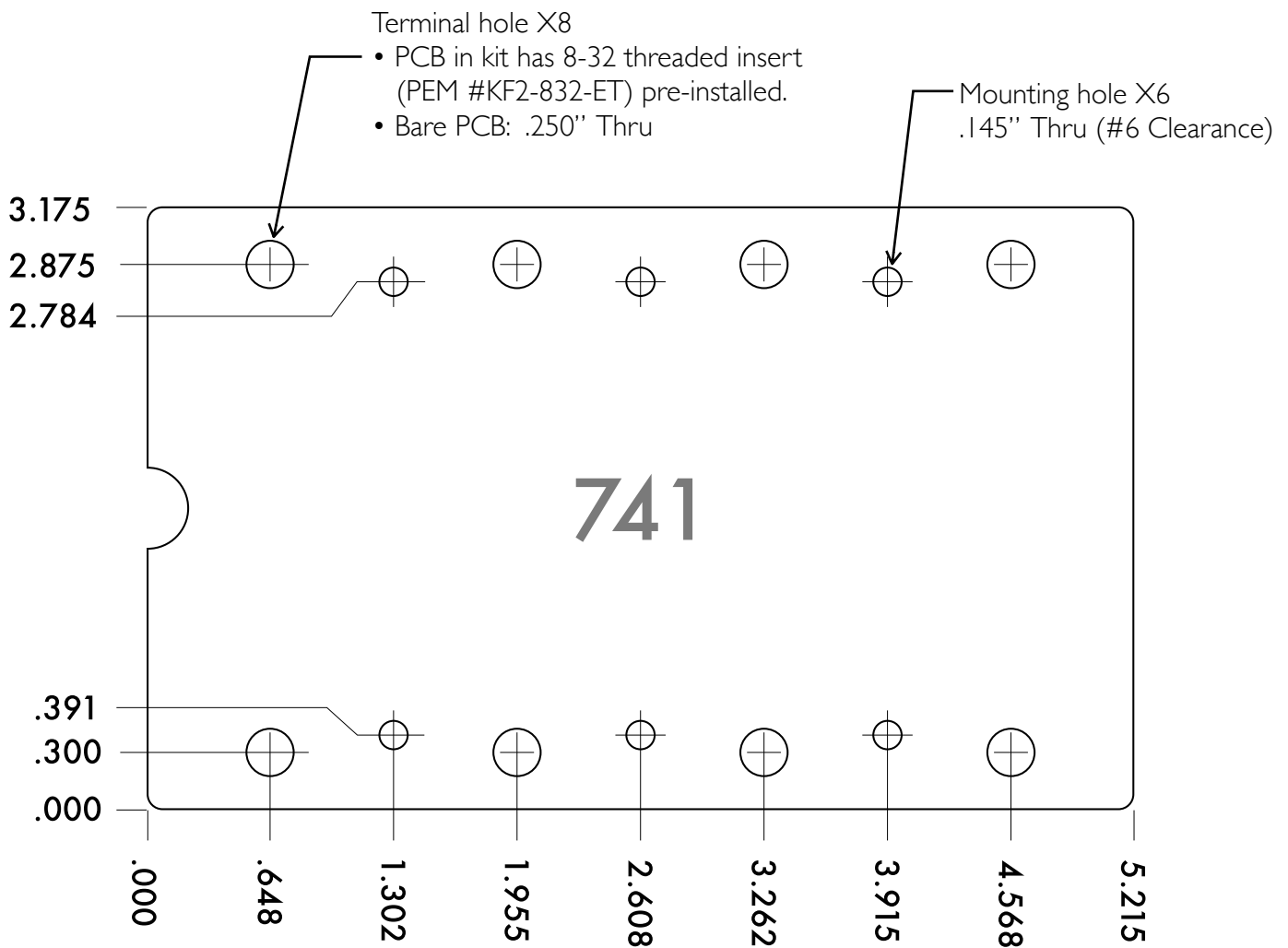

Note: All dimensions are in INCHES.

Additional physical specifications:

- Printed Circuit Board size: 5.215 X 3.175 inches (13.25 X 8.06 cm) wide
- PCB thickness: 0.100" (2.54 mm) nominal, not including threaded inserts
- PCB thickness: 0.196" (4.98 mm) nominal, including threaded inserts
- Overall thickness: Allow 0.5" min. clearance above and below circuit board
- Mounting holes: Six #6 clearance holes provided. See drawing for locations.
- Height of "DIP IC legs" stand: 1.25 inches (3.175 cm) nominal , not including spacers
- Height of "DIP IC legs" stand: 1.31 inches (3.33 cm) nominal , including spacers, to bottom of PCB.

741SE Package information: Circuit board physical layout and mounting holes

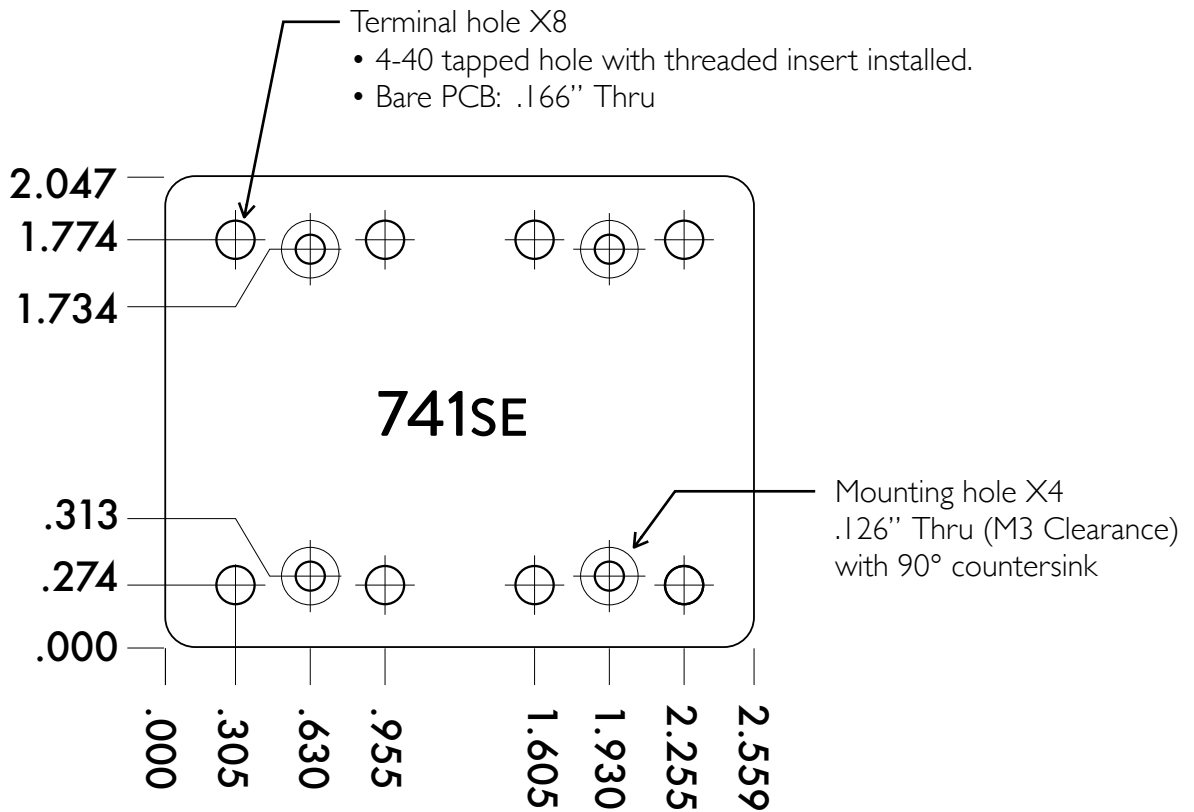

Note: All dimensions are in INCHES.

Additional physical specifications:

- Printed Circuit Board size: 2.559 X 2.047 inches (6.50 X 5.20 cm) wide
- PCB thickness: 0.062" (1.6 mm) nominal, not including threaded inserts
- PCB thickness: 0.125" (3.2 mm) nominal, including threaded inserts
- Overall thickness: Allow 0.25" min. clearance above circuit board for thumbscrews (if installed)
- Mounting holes: Four M3 countersunk clearance holes provided. See drawing for locations.
- Height of "SOIC legs" stand: 0.433 inches (11 mm) nominal, not including spacers
- Overall height: 0.80 inches (20.2 mm), from bottom of base to top of thumbscrews