

SB-GVS Shield V1.0

Arduino™ -Compatible Sensor Interface

Connect up to 18 peripherals to the popular Ground/Voltage/Signal interface. Got more? Use the I2C-interface too!

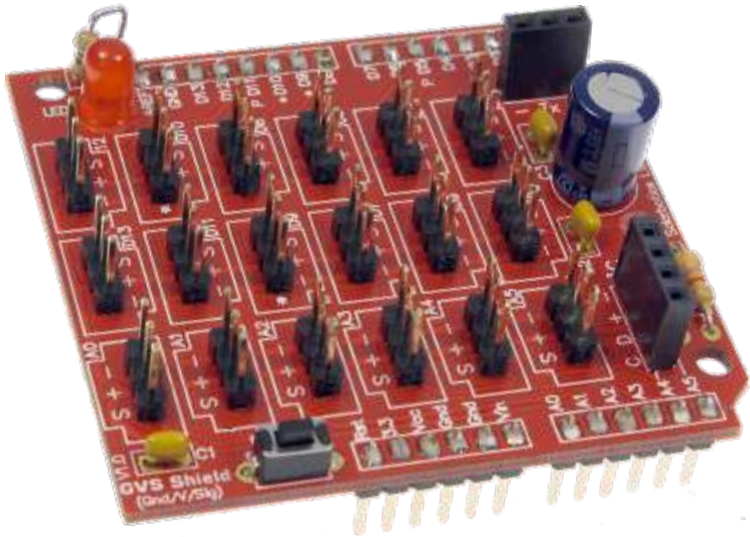

- Ideal for servo & sensor accessories (Phidgets, Seeed Bricks)
- Full break-out for all 12 digital lines & 6 analog lines
- BlinkM-style I²C port
- Power filtering & bypass capacitors
- Pin13 LED indicator
- Reset line brought up from Arduino
- Optional lock-tab sockets available for secure wiring



SOLARBOTICS®
Ltd

www.solarbotics.com

1-866-276-2687

SKU: 39230

DocRev: Dec0709

This is an intentionally blank page.
Y'know, for notes and pretty pictures and the like.

Parts List

- Printed Circuit Board (PCB)
- 1 x LED (Pin 13 indicator)
- 1 x 470 ohm resistors (Yellow / Purple / Brown)
- 1 x SWT10 Switch (reset)
- 3 x 0.1 μ F Ceramic Capacitors
- 1 x 330 μ F Electrolytic Capacitor
- 2 x 4.7k resistors (Yellow / Purple / Red - for I2C network)
- 1 x FPin3 3-position Female Header Socket Strip (Serial comm.)
- 1 x FPin4 4-position Female Header Socket Strip (I2C port)
- 2 x MPin36 36-pin Male Header Pin Strips (for snapping into 3's) or the optional 18 locking 3-position connectors (Part: *MPin3-Lock*)
- 2 x MPin6 6-pin Male Header Pin Strips for Arduino mounting
- 2 x MPin8 8-pin Male Header Pin Strips for Arduino mounting

Note: You will need your own Freeduino-SB or Arduino

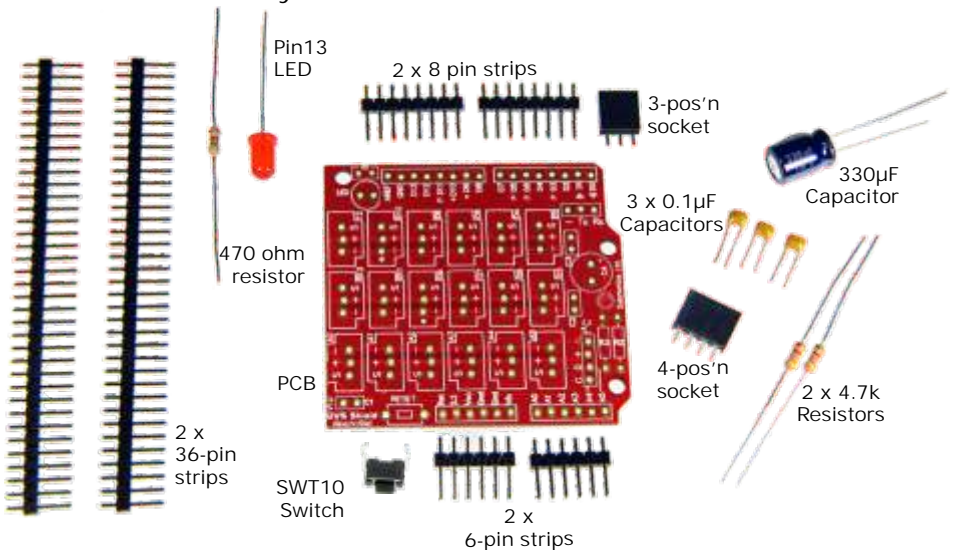

We strongly suggest you count the parts in your kit to make sure you have all the parts listed (c'mon - there's barely a handful of parts, so count them!). If anything is missing, contact Solarbotics Ltd. for replacement parts information.

Disclaimer of Liability

Solarbotics Ltd. is not responsible for any special, incidental, or consequential damages resulting from any breach of warranty, or under any legal theory, including lost profits, downtime, good-will, damage to or replacement of equipment or property, and any costs or recovering of any material or goods associated with the assembly or use of this product. Solarbotics Ltd. reserves the right to make substitutions and changes to this product without prior notice. Sorry - we hate legalese too, but "don't pick on us" doesn't impress the lawyers.

Construction!

You have an Arduino that wants sensors, so let's get to it!

Step 1 - Making the 3-Pin Headers: If you have decided to go with locking connectors, you can pocket the two sets of 36-pin strips and save them for a later project. You can *always* use more pin strips.

Count off pins in sets of 3 and snip them apart until you have 18 sets. If you are brave, snap them apart in your fingers, but it's easy to make a set of 2 or 4 instead of 3. You've been warned! There are more than enough pins in the strips to fix a mistake or two.

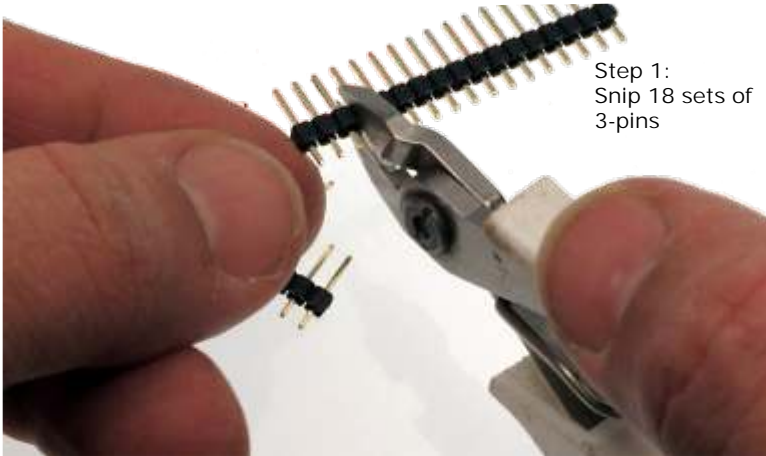

Step 1:
Snip 18 sets of
3-pins

Step 2 - Mounting the Sensor Pins: If you have the locking connectors, simply insert them according to the outlines. You'll notice that we reversed the orientation of the analog lines versus the digital lines for easier identification.

After you have the pins / locking connectors inserted in the holes, place a flat plate/book/CD case on top. Flip the whole mess upside-down so you can solder them in as a set instead of 1-by-1 (tedious!).

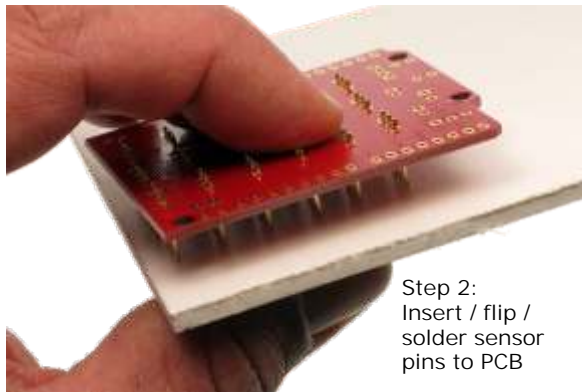

Step 2:
Insert / flip /
solder sensor
pins to PCB

Construction!

Step 3 - Install the Pin13 LED: What good is the Pin13 LED on the Arduino board if you can't see it? Exactly. That's why we're putting one here too.

Start with the LED. Match the flat-spot on the LED to the flat board printed on the printed circuit board (or insert the short LED leg into the square pad).

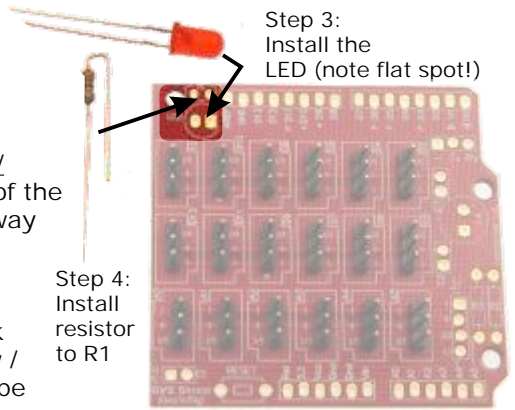

Step 4 - 470 ohm Resistor (Yellow / Violet / Brown): Fold over one leg of the resistor so it's pointing the same way as the other lead, and install it to position R1.

Don't get it confused with the 4.7k resistors which look similar (Yellow / Violet / Red). You want the 3rd stripe to be brown.

Step 5 - Install the 0.1 μ F Filter Capacitor: These capacitors help filter the power going to the sensors. Plug it in, flip it over, and solder it down!

Step 6 - Install Reset Switch: This is pretty simple - stick the reset switch into position "RESET", and solder it in! (Works best if installed top-side...)

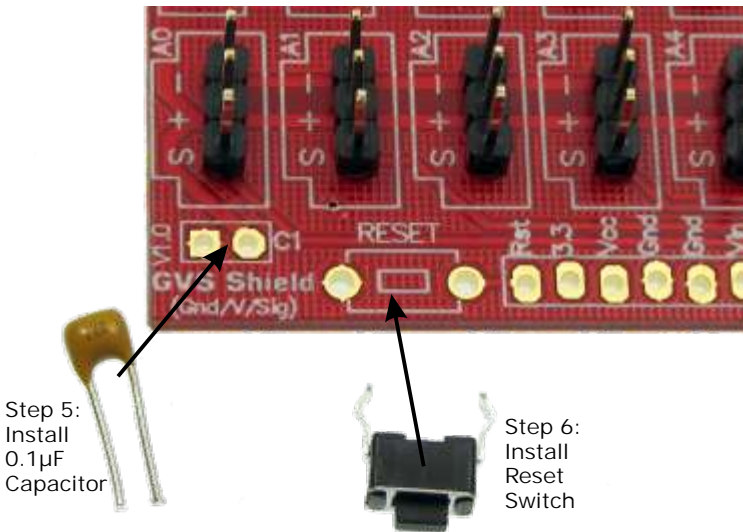

Construction!

Step 9 - Install the C2 & C3 0.1 μ F Capacitors: Just like C1, these are used to help filter power on the sensor power lines.

Step 10 - Install C4 330 μ F Electrolytic Capacitor: Unlike C1, C2 and C3, this one needs to go the right way in. Put the short lead (the one near the white stripe on the capacitor's body) into the square pad at position 'C4'. Just so you know, the long lead is positive, short lead negative.

Step 11 - Install the 4-position Socket Strip: This will be useful when you're plugging in I²C accessories, like a BlinkM Smart LED.

Note: Using the I²C port means you can't use A4 or A5 pins. A4 and A5 share their pins with the I²C feature, and they can't be used at the same time.

Step 12 - Install the 4.7k (Yellow / Violet / Red) I²C Pull-up resistors: These are *not usually* required, but some I²C peripherals will behave better with these installed. It won't hurt to put them in now, so why not? Install them to locations 'R2' & 'R3'.

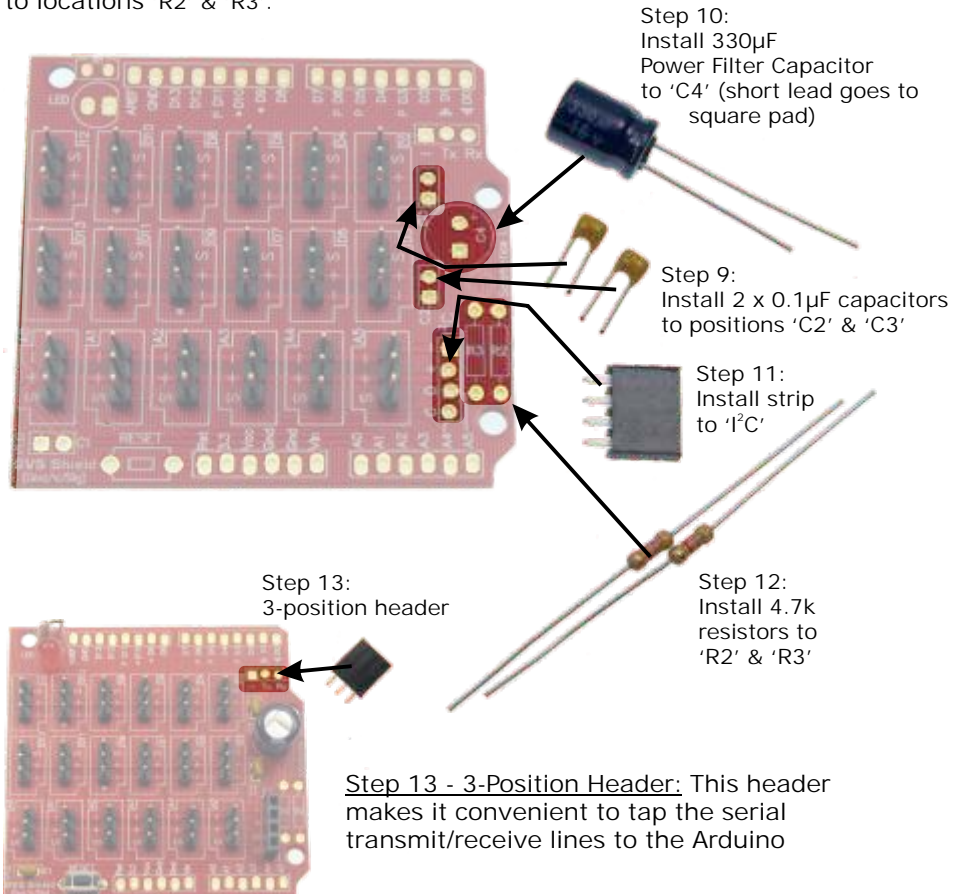

Construction!

Step 14 - Install the 6 & 8 Pin Male Header Pins: There are a few ways to install the mating pins. One is to put the male pins into the mating sockets of your host microcontroller, then put the shield on top and solder it in. We only recommend this method if you're good at soldering! Too much heat, and you'll melt the Arduino sockets!

We suggest you tack solder *one* pin, manually tweak the alignment so it's straight up and down, and then solder in the rest of the pins (It's how we recommend you do it in the Freeduino-SB assembly documentation).

Step 14: 8-Pin strips go to the upper pads, and the 6-pin strips go to the lower.

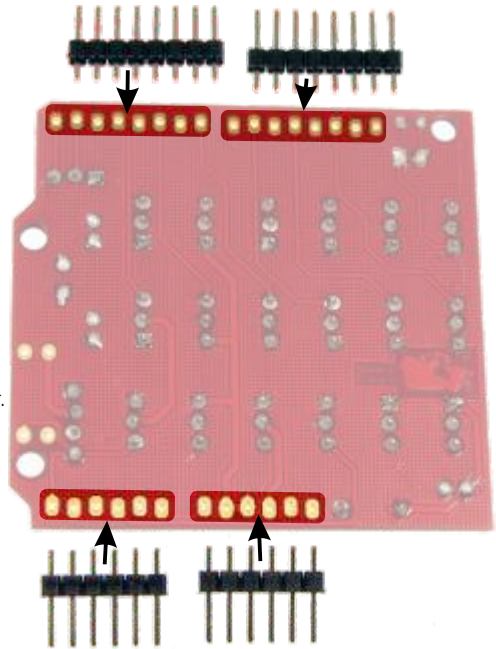

You are finished! Plug your SB-GVS shield into your Arduino / Freeduino, and you'll have a whole board to attach sensors to! We have tutorials and sample code on Solarbotics.com for this shield, so check if you are not sure what to do with it, check out our examples!

The SB-GVS Shield for the Arduino / Freeduino

What's a Shield?

If you're talking about fighting, it's an beefed-up garbage can lid. In regards to *Arduino*, it's a plug-in board that offers extra features to the main microcontroller board.

Ok, so what's a SB-GVS Shield?

You know servos? They have 3-wire connections: Ground / Voltage / Signal. This standard has been adopted by *many* manufacturers for their peripherals and sensors. Look specifically at Phidget sensor modules and Seeed Studios "Brick" sensor units. And practically *any* hobby-servo on the market.

The SB-GVS Shield offers:

- Breakout points to all 12 Arduino digital I/O
- Breakout points to all 6 Arduino analog I/O
- Convenient BlinkM compatible I²C port
- Tx/Rx/Gnd serial communication port
- Arduino Pin 13 LED & Reset button are brought up to the shield
- Power filtration capacitors for smooth accessory operation

Options!

Don't forget that if you like to have secure connections, get the locking plug pack (part *Mpin3-Lock-GVS*), which has 16 locking sockets for lock-tab plugs.

If you like to extend the functionality of your shield by stacking, or you want to have another tap-point for the Arduino I/O lines, you'll like the 6-pin and 8-pin long-plug/pin sets (parts *Fpin6L-413* / *Fpin8L-413*).

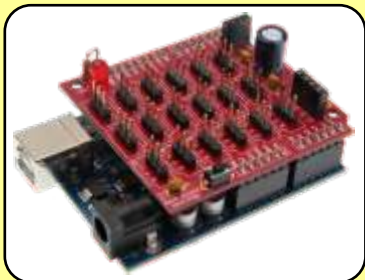

SB-GVS Shield on Arduino

SB-GVS Shield built with [locking plug connectors](#) (part # Mpin3-Lock)

Visit us online for more info and cool stuff:

www.solarbotics.com

Solarbotics Ltd.
201 35th Ave NE
Calgary, Alberta T2E 2K5
Canada



Toll Free: 1-866-276-2687
International: +1 (403) 232-6268

Fax: +1 (403) 226-3741



Made in Canada